

T&M applications, hot switching is not a requirement for ATE as the test system and test plans are fully within the operator's control.

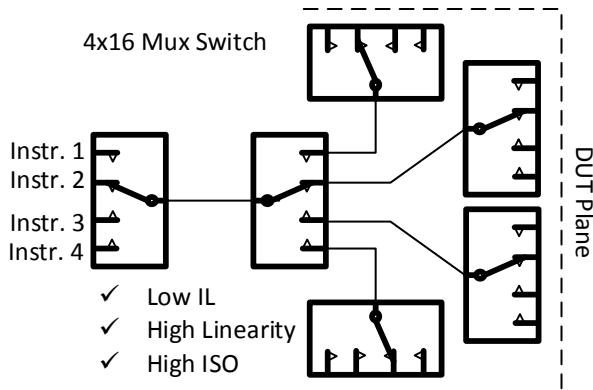

Fig. 2 an ATE mux switch configuration.

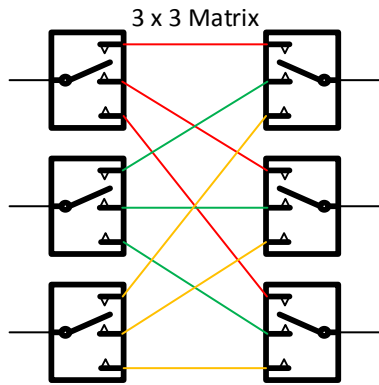

Fig. 3 A typical 3x3 ATE switch matrix.

As the pressure for reducing the cost of test continues to grow in order to meet market demands, there is a strong desire to eliminate EM switches from T&M instrumentation and semiconductor ATE systems. With solid state switches clearly not up to the challenge yet, RF MEMS switches may finally bridge the gap between EM and solid state switches. A systematic approach to identify and quantify the material, mechanical and electrical failure modes associated with MEMS switches has led to the development of a high-power, reliable RF MEMS switch.

III. FAILURE MODE ANALYSIS OF RF MEMS SWITCHES

The approach towards reliable MEMS switch development requires identification of the separate failure mechanisms associated with the structure of the cantilever beam and the ohmic contact depicted in Fig. 4. An RF MEMS switch capable of handling greater than 10W requires materials with mechanical properties similar to silicon but with the conductivity of metal. While metals are excellent conductors, most pure metals are not capable of acting as good spring materials. Pure metals fail to resist time and temperature dependent deformation, a property critical for repeatable micro device operation and consistent performance

[4]. A Ni alloy and Au alloy were developed to enable highly conductive structurally stable spring elements. The Ni alloy has demonstrated high conductivity with tensile strengths greater than 1GPa, which is roughly ten times greater than that of pure metals like Au, Cu, and Al. We have characterized both alloys for their time-dependent mechanical behavior in comparison to other materials. Micro-tensile measurements were used to extract and validate materials parameters, such as activation energy and activation volume, that predict an actuator life greater than 10 years at 85C under a load of 120MPa.

While the beam is sensitive to deformation, the quality of the contact is a function of surface conditions such as material adhesive force, the buildup of surface monolayers and induced thermo-mechanical stress. An increase in contact interface adhesion can overcome the restoring force of the beam. Deposited surface monolayers cause a gradual increase in contact resistance. Finally, thermo-mechanical stress results in physical wear of the contact material and gradual increase in resistance and adhesion force. Ruthenium has been found to be an ideal material to overcome contact failure due to its hardness, high melting voltage and low adhesion energy, enabling the contacts to withstand billions of switching cycles.

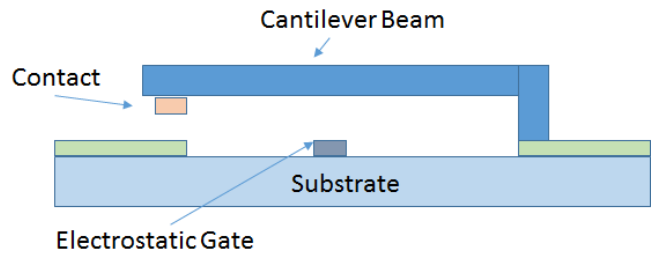

Fig. 4 A cross section diagram of a cantilever based switch.

IV. RESULTS

Resistance to permanent creep deformation during operation is a requirement for metal cantilever style MEMS switches to maintain consistent mechanical performance and minimize change to the switches voltage breakdown. If the cantilever beam material cannot withstand operating stresses during switching cycles, the contact gap in the 'off' state can decrease to such an extent that the switch itself no longer functions (i.e. it remains 'on' even without an applied gate voltage). The electroplated Ni alloy has a yield strength >1 GPa and a resistivity around 7×10^{-6} Ohm-cm. The alloy's nanocrystalline grain structure (<10 nm) has been extensively characterized through transmission electron microscopy analysis. The alloy's composition was engineered to maintain both grain stability and minimal strain rate for typical MEMS loads at operating temperatures up to 500 °C, as shown in Fig 5. Stress relaxation tests determined a strain rate profile and quantified the material specific parameters used to model and predict time-dependent deformation of a suspended microstructure under load. The model was experimentally validated by accelerating the beam failure modes through combined elevated stress (600MPa) and temperature testing of cantilever switches. A Larson Miller plot in Fig. 6 shows

only a few % change in cantilever deformation of the Ni alloy switch tested at elevated load and temperature up to 300C for extended time. Switches were actuated at temperatures ranging from 100C to 300C to accelerate the creep based deformation. The accelerated data was referenced back to 85C which demonstrated more than 20 years of operational life even under an excessive 600MPa actuation load. More importantly the data collapsed into a single trend line which indicated that the Ni alloy switch exhibited only time and temperature based deformation (creep) and no other deformation mechanisms. Au and Ni alloys have been used to create creep resistant cantilever structures for RF MEMS switches based on these results.

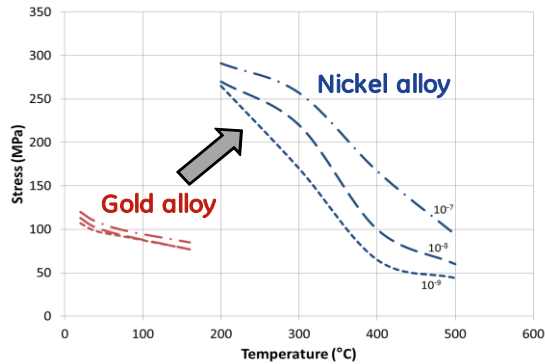

Fig. 5 Strain rate as a function of applied stress derived from the raw load-time data.

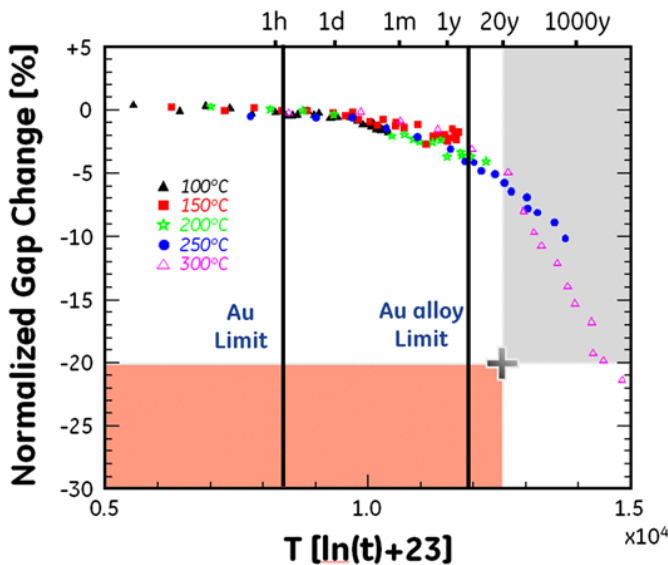

Fig. 6 A Larson Miller plot showing measured gap change of a Ni alloy cantilever switch under elevated load of 600 MPa with elevated temperature referenced to an acceleration factor based on 85C. Predicted Au and Au alloy limits shown for reference.

Stable and consistent insertion loss is a function of the contact material and its ability to resist failure mechanisms. Films with increased hardness are less susceptible to grain boundary voiding, as a result of switch closing operations that lead to resistance increase and cycle fatigue failure from material transfer. Au, while being one of the least resistive

metals, is also one of the softest materials making it ideal for conduction but a poor choice for mechanical wear resistance. Ruthenium, a slightly more resistive material than Au, has a hardness measured at nearly 15GPa, which is an order of magnitude greater than Au. The ruthenium surface and its surrounding hermetic environment can be engineered to minimize contaminant monolayer build up that gradually increases contact resistance with every switch cycle [5]. The ruthenium contact performance is demonstrated in Fig. 7 where the resistance of a multi cantilever beam array is low and stable for more than 10B cycles. To enable hot switching in RF MEMS, a contact material with high melting voltage is necessary to resist thermo-mechanical degradation. The melting voltage is the voltage at which the contact surface interface atoms will transition to the liquid phase due to the voltage induced energy dissipated from the contacts parting. Ruthenium has one of the highest values among the platinum family of metals, at 0.8V. To experimentally test this, we have hot switched an RF MEMS device with 30 dBm at 1 GHz and recorded the variation of IL vs. switching cycles as shown in Fig. 8. The data demonstrates that IL changed less than 0.005 dB over 2.2M cycles.

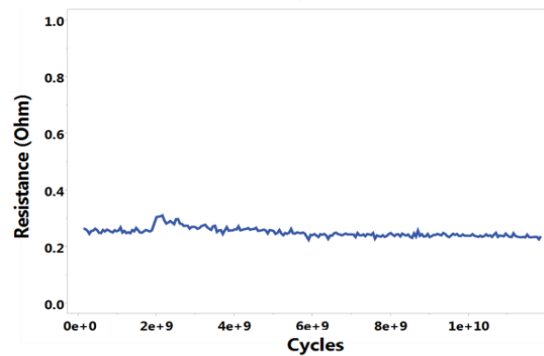

Fig. 7 Plot of resistance vs. cycles of a multi beam MEMS switch array containing ruthenium contacts that demonstrate stable DC contact resistance below 0.3ohm for more than 10B cycles.

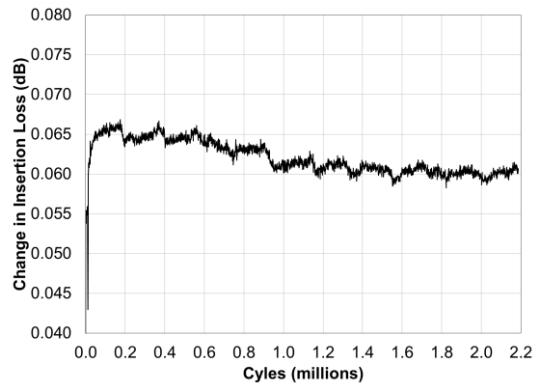

Fig. 8 Plot of IL repeatability vs. cycles at 30dBm hot switch demonstrates the ruthenium contacts ability to sustain consistent IL for millions of cycles.

A high-performance and stable material platform and fabrication process has been developed for ohmic RF MEMS

switches. Various switch configurations can be designed and tailored for application specific needs with this platform. The insertion loss of a single unit cell RF MEMS switch with 2mm of coplanar waveguide demonstrated less than 0.3dB of IL and isolation (ISO) better than 30dB up to 6GHz as show in Fig. 9 and Fig. 10, respectively. The switch platform allows the design of high density, low power (<10W) switch configurations as well as single channel high power designs capable of transmitting up to 50W. Table 1 shows measured IL data for input power levels ranging from 1W to 50W. The combination of a low loss, highly reliable, 25W, RF MEMS switch capable of hot switching 30 dBm has been developed in a low cost, low profile 6x6mm land grid array package as shown in Fig. 11 for T&M and ATE applications.

TABLE 1. Measured IL vs. excitation power

Input Power @ 900MHz	SPST LGA and Assembly loss
1.76W	0.36 dB
5.30W	0.34 dB
15.88W	0.38 dB
49.20W	0.39 dB

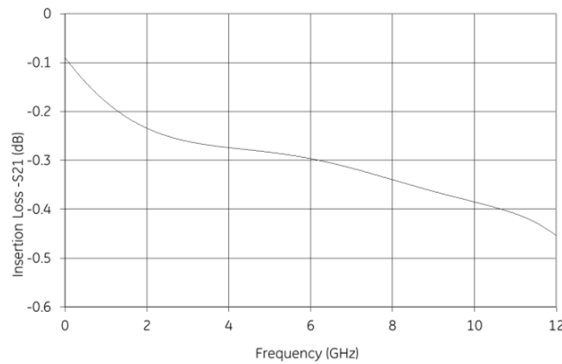

Fig. 9 Measured IL of a single unit cell RF MEMS switch.

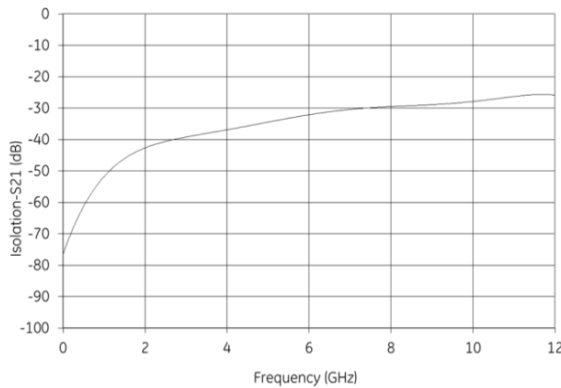

Fig. 10 Measured isolation of a single unit cell RF MEMS switch.

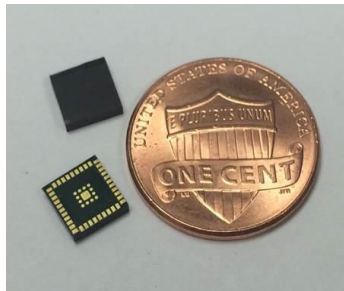

Fig. 11 A 6 channel, 25W, SPST, RF MEMS switch in a land grid array package.

V. CONCLUSION

Ohmic RF MEMS switch with creep resistant Au and Ni alloy beams, and a highly reliable ruthenium contact has been developed based on methodical failure mode analysis taking into account material, mechanical and electrical constraints. The robust materials and processes enable a platform of switching MEMS elements that can be customized to target various DC to RF applications. These switches demonstrate reliable hot switching at 30 dBm and high power handling to 25W, which make them suitable candidates for replacement of at least some EM switches currently used in T&M and ATE applications.

References

- [1] Keimel, C.; Claydon, G.; Bo Li; Park, J.; Valdes, M.E., "Micro-Electromechanical System (MEMS) based switches for power applications," IEEE Transactions on Industry Applications, vol. 48, issue 4, pp.1163-1169, (2012)
- [2] P. Bacon, D. Fishcer, and R. Lourens, "Overview of RF Switch Technology and Applications" Microwave Journal, July 2014, pp. 76-88.
- [3] G.M. Rebeiz, C. D. Patel, S. K. Han, C. H. Ko, and K. M. J. Ho, "The Search For A Reliable MEMS Switch?", IEEE Microwave Magazine, Jan/Feb 2013, pp 57-67.
- [4] Krogstad, J.A.; Keimel, C.; Hemker, K., "Emerging materials for microelectromechanical systems at elevated temperatures", Journal of Materials Research volume 29, issue 15, pp.1597-1608, (2014)
- [5] Brand, V., Baker, M., de Boer, M., "Impact of Contact Materials and Operating Conditions on Stability of Micromechanical Switches", Tribology Letters, vol. 51, issue 3, pp.341-356, (2013)